

INTERNATIONAL STANDARD

ISO
3078

Second edition
1987-06-01



INTERNATIONAL ORGANIZATION FOR STANDARDIZATION
ORGANISATION INTERNATIONALE DE NORMALISATION
МЕЖДУНАРОДНАЯ ОРГАНИЗАЦИЯ ПО СТАНДАРТИЗАЦИИ

Shipbuilding — Cargo winches

Construction navale — Treuils de charge

Reference number
ISO 3078 : 1987 (E)

Foreword

ISO (the International Organization for Standardization) is a worldwide federation of national standards bodies (ISO member bodies). The work of preparing International Standards is normally carried out through ISO technical committees. Each member body interested in a subject for which a technical committee has been established has the right to be represented on that committee. International organizations, governmental and non-governmental, in liaison with ISO, also take part in the work.

Draft International Standards adopted by the technical committees are circulated to the member bodies for approval before their acceptance as International Standards by the ISO Council. They are approved in accordance with ISO procedures requiring at least 75 % approval by the member bodies voting.

International Standard ISO 3078 was prepared by Technical Committee ISO/TC 8, *Shipbuilding and marine structures*.

This second edition cancels and replaces the first edition (ISO 3078: 1974), of which it constitutes a minor revision.

Users should note that all International Standards undergo revision from time to time and that any reference made herein to any other International Standard implies its latest edition, unless otherwise stated.

Shipbuilding — Cargo winches

1 Scope and field of application

This International Standard specifies the characteristics of cargo winches on cargo derricks, especially winches with electric or hydraulic drive.

2 References

ISO 2408, *Steel wire ropes for general purposes — Characteristics.*

ISO 3828, *Shipbuilding and marine structures — Deck machinery — Vocabulary.*

ISO 6482, *Shipbuilding — Deck machinery — Warping end profiles.*

ISO 7825, *Shipbuilding — Deck machinery — General requirements.*

3 Definitions

For the purposes of this International Standard, the definitions given in ISO 3828 and the following definitions apply.

3.1 cargo winch: Winch used for hoisting and lowering cargo. (Definition repeated from ISO 3828.)

3.2 nominal size: Size which corresponds to the nominal load, i.e. the maximum working load at the hook, in tonnes, which the winch is rated to lift in direct operations (with a single sheave at the derrick-head and a single sheave at the foot — see figure 1).

Winches are graded according to their nominal size as given in the table (see clause 5).

If the winch has reduction gear with several gear ratios, each step shall correspond to a nominal load in the table.

NOTES

- 1 The nominal sizes are derived from the preferred number series.
- 2 The definition of the nominal size given above is not applicable to heavy derricks.

3.3 nominal speed of hoisting: Speed at which the winch is capable of lifting the nominal load.

The minimum nominal speeds of hoisting are given in the table (see clause 5).

3.4 drum load: Maximum rope tension, in kilonewtons, measured at the drum exit when the winch is hauling in at the nominal speed with the rope wound on the drum in a single layer. (Definition repeated from ISO 3828.)

NOTE — The drum load is approximately 11 times the nominal load measured in tonnes. The factor of 11 takes account of the loss through friction due to the sheaves and of the ratio between force in kilonewtons and mass in tonnes.

3.5 Right-hand and left-hand cargo winches

3.5.1 right-hand winch: Winch where the reduction gear or the drive for the drum is on the right-hand side of the drum in relation to an observer situated on the side of the motor, power supply or controller (in the case of a symmetrical winch). (See figure 2.)

3.5.2 left-hand winch: Winch where the reduction gear or the drive for the drum is on the left-hand side of the drum in relation to an observer situated on the side of the motor, power supply or controller (in the case of a symmetrical winch).

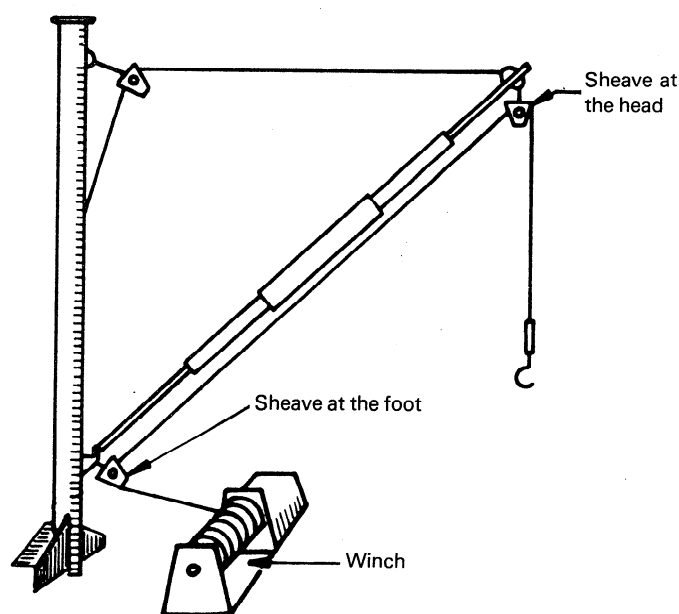

Figure 1 — Example of use of a winch